

HiSec² 6

Motorised security booth for internal or semi-external installation

HiSec is a security product in the Gunnebo Turnstiles offering. The HiSec² 6 has a transparent and elegant design offering a choice of security levels preventing tailgating and piggybacking.

The doors are always locked shut in the rest position. An authorised signal opens the first door allowing the user to step into the booth where a presence is detected. When the first door is closed, the second door opens, thus allowing the user to pass through. The second door shuts after the unit has been vacated which also resets the system.

The HiSec detects with an electronic ultrasound sensor if more than one person is present inside the booth.

The booth is set with a predetermined, but adjustable anti-hostage threshold. As an authorised user stands in the booth, it confirms acceptance of the occupant and authorises the door to close. Should the measured volume presence not be authorised, i.e. more than one person is present non-permitted big additional baggage, a vocal synthesiser will ask the occupants to leave the booth.

An additional left object sensor is able to detect on the floor the presence of an object of the size of 50x50x30mm.

The HiSec is equipped with a electronic safety features that reverses the motor to re-open the door upon detection of an obstruction. The door fully opens to allow the obstruction to be removed after which it attempts to re-close.

Drive

Motorised security booth that is connected to a ratio motor operated by a direct current engine with regulated speed.

Electronic frame along the profiles and safety torque sensing.

Materials

Structure: Embossed painted steel section powder coated finish
RAL color 9006

Glass: Lite:
11/12 mm laminate Safety Glass P4A BR1/S
(in accordance with EN356-EN1063) - Safety Manifestation on moving glass doors
Bullet proof:
26/27 mm laminate Safety Glass P6B BR3/S
(in accordance with EN356-EN1063) - Safety Manifestation on moving glass doors

Ceiling: Laminated HPL finished Pearl Grey

Base Plate: High-strength laminate with finishing in colour Plumb Grey

Sliding door: Printed frame in polyethylene terephthalate RAL 7040

Light

A low voltage light is positioned internally on the ceiling.

Detection

The HiSec booth is equipped with a ultrasound system which determines if more than one person is present inside the booth.

Power failure / Fire alarm

In the event of a power failure, isolation or after the BBU has been depleted, the outer, un-secure door will fail safe, i.e. unlocked and can be manually pushed open. The inner, secure door will fail lock and is held in place via a lever system situated behind a locked panel above the door on the secure side of the installation. The inner door can be manually opened by rotating a knob located behind the lockable service panel in the top mechanism section of the booth.

TECHNICAL DATA

- **Power Supply:** 230 VAC 50Hz or 115 VAC 60Hz
- **Power Rating:** 230 VAC -1,4 A 115 V AC 2,8 A
- **Logic Voltage:** 24 V DC
- **Operating Temperature:** 0° to +50°
- **IP rating/ MCBF/MTTR** IP33/1,5M cycles / less than 30 min
- **Flow Rates (approximate figures):**
Proximity Reader "Hands Free", 4 passages per minute

MODELS

- HS6L 12 mm glass
- HS6LM 12 mm glass, metal detector

OPTIONS

- Metal detector
- Alternative finishes
- Demountable version kit
- Horizontal transportation kit
- Fail safe opening
- Glass security upgrade on request
- Left object sensor
- Contact mat
- Weighting Sensing Upgrade
- BR2 / BR3 / BR4 - EN1063
- RC2 / RC3 - EN1627

BENEFITS

- Premium high security solution
- Elegant design
- Reliable performance
- No architectural browser "base only 20mm"

APPLICATIONS

- Head Offices
- Banking
- Data Centres
- Telecommunications
- Information Technology
- R & D
- Government
- Military
- Security Publishing
- Law Enforcement

SITE PREPARATION: HiSec 6L / 6B

Product is delivered in fully assembled and requires lifting equipment. Approx. Weight 530 Kg
For installation details, please refer to installation layout drawings)

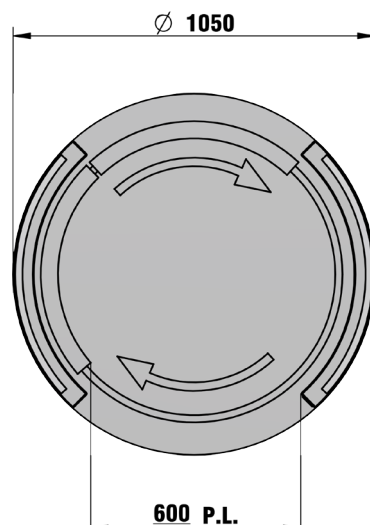
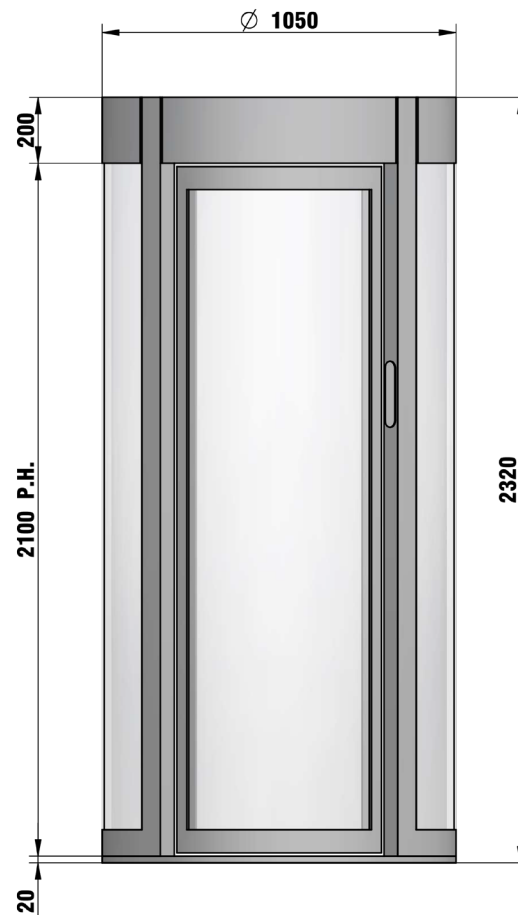

Concrete Base to specification at least (cube) 30N/mm² of resistance. Base to be flat and level to +/-5mm over footprint area.
Dimensions to be > 1150 x 1150 x 150 deep min. (units in mm).

IMPORTANT

- Any horizontal pipe or conduit running below the MTR must be at least 140 mm below FFL
- Metal conduit for cables should be raised at least 50 mm from foundation
- It is the customer's responsibility to ensure the structural integrity and strength of the installation location
- The dimensions given in this Product Data Sheet are for information only. In order to prepare the installation site, please refer to your usual Gunnebo Customer Service contact

CONDITION OF USE

When using Gunnebo's security access control gates, for security reasons, children must be supervised by an adult at all times.

For further information, please contact:
Gunnebo Entrance Control Ltd

Tel: +44 1825 761 022
Fax: +44 1825 763 835
Email: info.entrancecontrol@gunnebo.com

The data given in this material may be subject to change without further notice. The Gunnebo logo and "Gunnebo - For a safer world" are registered trademarks of Gunnebo AB. See www.gunnebo.com for more information.